

# PolyDrain<sup>®</sup>

Polymer Concrete

PDX<sup>®</sup>

Versatile Modular Trench System



Industrial Mechanical Applications



Complex System Layouts



Stormwater Site Applications

[www.abtdrains.com](http://www.abtdrains.com)

Today's Hydraulic Solutions



**ABT, INC.**  
Advanced Building Technologies, Inc.

# PolyDrain® PDX®

Over the years the PolyDrain® name has become synonymous with trench drain design. Architects and Engineers, recognizing the benefits of pre-engineered polymer concrete trench drains, have specified ABT's PolyDrain® line for over 30 years. Building on this legacy, ABT, Inc. now manufactures PolyDrain® PDX®; a polymer concrete trench drain system available in varying widths and slopes for an even wider variety of

applications and uses: food and beverage processing plants, industrial manufacturing facilities, waste water treatment plants and chemical processing plants.

PolyDrain® PDX® polymer concrete trench drain assures the precision, accuracy and design flexibility required to satisfy practically any load, hydraulic, or chemical resistance demands. In addition, expensive labor and material costs associated with hand-forming and other demanding installation methods are eliminated.

## Product Features

**Channels** - PDX polymer concrete channels are available with interior widths of 6" [152mm], 8" [203mm], 10" [260mm], 12" [305mm], 15" [381mm], 18" [457mm], and 24" [609mm]; available in depth increments of .197" [5mm] up to 19.69" [500mm] channel depth. The channels are available either non-sloping or with sloped in 0% to 4% in 0.5% increments are available. Each channel features a high precision tongue and groove joint for positive alignment and superior configuration for sealant when the application requires.

### Ease of Installation -

Installation does not require heavy equipment, expensive highly-skilled labor, keyways, or water stops; it even allows for elevation adjustments prior to the final concrete placement: potentially saving 33% or more of total installation and material costs compared to conventional hand forming methods.

### Eliminates Sub-Slab Barrier Penetration -

Utilizing ABT's no-float U-legs and horizontal suspension eliminates the need of penetrating a sub-slab barrier to support or position the trench drain during installation.

### Flammability and NFPA Codes -

Trench drains are often the collection point for flammable liquids and heavier than air vapor, and can contribute to the spread of fire. Selecting a trench drain with the proper material properties is critical to the life cycle of the product and life safety of a buildings inhabitants.

ABT® Inc's Polyester Polymer Concrete products carry the UL-723 Classified mark for Class A fire rating and are ULC listed. Demand a UL Classified / ULC Listed product.

## PolyDrain® PDX® Formulations

ABT® offers two compositional formulations for PolyDrain® PDX® channels, depending on the effluent and chemical environment. Both offer superior strength and durability as well as marked cost advantages over alternative materials.

Standard PolyDrain® PDX® channels are manufactured from PolyDyn®, an advanced formulation of selected aggregates and inert mineral fillers bonded together in a high-grade polyester resin. This formulation is suitable for use in both exterior and interior applications and are UL Classified and ULC Listed.

When a higher level of chemical resistance is required, ABT® offers PolyDrain® PDX® in a special formulation called PolyChampion®, which has the same aggregates and mineral fillers as the PolyDyn® formulation, but with a premium grade vinylester resin binder. This formulation will withstand a broader range of corrosive salts, fuels, acids and alkalis.

*Please see chemical resistance guide.*

Fluid	PolyDyn	PolyChampion	Portland Cement
Water	•	•	Permeable
Gasoline	•	•	Permeable
Diesel Fuel	•	•	Permeable
Aviation Fuel	•	•	Permeable
Hydraulic Oil	•	•	Permeable
Fuel Oil	•	•	Permeable
Hydraulic Fluid	•	•	Permeable
Motor Oil	•	•	Permeable
Sea Water	•	•	Permeable
Acids		•	Corrodes
Road Salts	•	•	Corrodes
Caustic		•	Corrodes

### Physical Properties of PolyDyn® Thermoset Polyester Polymer Concrete

Property	Test Method	Value
Compressive Strength	ASTM C579	17,000 psi Minimum
Bending Strength	ASTM C580	4,000 psi Minimum
Tensile Strength	ASTM C307	2,000 psi Minimum
Moisture Absorption	ASTM C140	0.1% Maximum
Freeze/Thaw (1,600 cycles)	ASTM C666	No Weight Loss
Fungi Growth Resistance	ASTM G21	Zero Mold Growth
Flame Spread - UL/ULC	UL 723	Class A

# Design Chart Instructions

Available Widths: 6", 8", 10", 12", 15", 18", 24"  
Available Channel Depths: 3.94" - 19.69"  
Slopes: 0% to 4% in 0.5% increments



## Utility Trench -

Select the width and depth sufficient to contain the application's wire or pipes for each run. Select materials and the style of cover desired.

## Containment or Storage Trench -

The wide range of sizes, depths and chemical resistance characteristics make PolyDrain PDX is an ideal product for containment and storage applications. Use the 'Trench Storage Capacity' table on page 5 to find which trench widths and depths provide sufficient storage and select the one that is best for the application.

## Grate Options -

A wide range of grate options exist for pedestrian to airport applications. Select grates with the right strength, style, and corrosion resistance for the application.

## Frame Options -

Steel, stainless steel, painted steel, galvanized steel, or FRP styles are available. Select the best rail material for your application. All rails are independently anchored and supported by the into the surrounding concrete so that the encapsulation concrete receives the loads, not the channel walls.

## Variable Grate Retention Systems -

For applications with substantial longitudinal loads, pin locks are available and recommended. Toggle locks can be used when longitudinal loads are low. No grate lock is an option where horizontal forces and grate retention are not a consideration. ABT can assist you in making a suitable selection.

## Catch Basins -

Adaptable catch basins are available to accommodate various outlet piping requirements.

## Installation Eliminates Sub-Slab Barrier Penetration -

The system is installed by the suspension method using no-float legs. Installing the system does not require heavy equipment, expensive highly skilled labor, keyways, or water stops saving 33% or more. Installed per instructions, the system will not float. Utilizing the suspension method eliminates the need of penetrating a sub-slab barrier to support or position the trench drain during installation.

Contact ABT, Inc. for special requirements

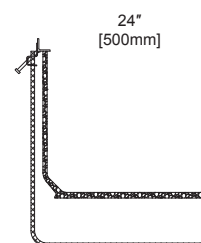
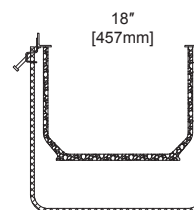
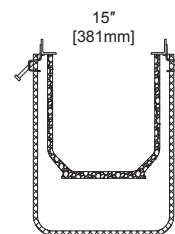
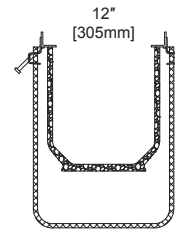
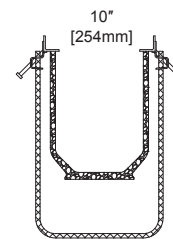
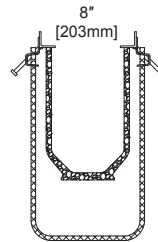
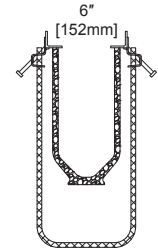

# Drainage Trench

Lay out the trench run(s) for the site. For each run, determine and divide the maximum storage volume required by the length of the trench. Use the table below to determine which trench widths and depths provide sufficient storage and select the one that is best for the application.

## PDX Run Length vs. Slope

### Channel Slope Run Lengths

Channel Slope	Run Length Channel / Meters	Run Length Feet
0.5%	80	262.5
1.0%	40	131.2
1.5%	27	87.6
2.0%	20	65.6
2.5%	16	52.5
4.0%	10	32.8

**Note:** Intermediate slopes in 0.5% increments between those shown above are possible with decreased run lengths. Non-sloped trenches are available in .197" [5 mm] depth increments. Contact ABT for availability and additional information.



### PDX Flat Site Flow Capacity & Velocity / 19.69" Deep Channel

Invert Slope	6"			8"			10"			12"			15"			18"			24"		
	GPM	CFS	FPS	GPM	CFS	FPS	GPM	CFS	FPS	GPM	CFS	FPS	GPM	CFS	FPS	GPM	CFS	FPS	GPM	CFS	FPS
0.5%	1391	3.10	3.86	2289	5.10	4.74	3321	7.40	5.50	4533	10.10	6.22	6631	14.70	7.10	8977	20.00	8.18	14587	32.50	9.96
1.0%	1975	4.40	5.48	3232	7.20	6.69	4713	10.50	7.80	6418	14.30	8.81	9378	20.90	10.20	12702	28.30	11.58	20601	45.90	14.06
1.5%	2424	5.40	6.72	3950	8.80	8.17	5790	12.90	9.50	7855	17.50	10.78	11486	25.50	12.50	15574	34.70	14.20	25269	56.30	17.25
2.0%	2783	6.20	7.72	4578	10.20	9.47	6688	14.90	10.90	9111	20.30	12.50	13263	29.50	14.40	17998	40.10	16.41	29174	65.00	19.91
2.5%	3142	7.00	8.71	5117	11.40	10.59	7451	16.70	12.20	10144	22.60	13.92	14829	33.00	16.20	20108	44.80	18.33	32585	72.60	22.24
4.0%	3950	8.80	10.95	6463	14.40	13.37	9470	21.10	15.50	12881	28.70	17.68	18757	41.80	20.30	25449	56.70	23.20	41248	91.90	28.16

### PDX Flat Site Flow Capacity & Velocity for 500mm Deep Channel

Invert Slope	152 mm			203 mm			254 mm			305 mm			381 mm			457 mm			610 mm		
	LPS	CMS	MPS	LPS	CMS	MPS	LPS	CMS	MPS	LPS	CMS	MPS	LPS	CMS	MPS	LPS	CMS	MPS	LPS	CMS	MPS
0.5%	88.70	0.09	0.08	144.50	0.14	0.08	210.80	0.21	0.08	286.60	0.29	0.54	417.20	0.42	0.54	566.70	0.57	0.54	917.90	0.92	0.54
1.0%	125.50	0.13	0.12	204.40	0.20	0.12	298.10	0.30	0.12	405.40	0.41	0.76	590.00	0.59	0.76	801.40	0.80	0.76	1298.20	1.30	0.76
1.5%	153.70	0.15	0.14	250.40	0.25	0.14	365.10	0.37	0.14	496.50	0.50	0.94	722.70	0.72	0.94	981.50	0.98	0.94	1590.00	1.59	0.94
2.0%	177.40	0.18	0.17	289.10	0.29	0.17	421.60	0.42	0.17	573.30	0.57	1.08	834.50	0.83	1.08	1133.40	1.13	1.08	1835.90	1.84	1.08
2.5%	198.40	0.20	0.19	323.30	0.32	0.19	471.40	0.47	0.19	641.00	0.64	1.21	933.00	0.93	1.21	1267.20	1.27	1.21	2052.70	2.05	1.21
4.0%	251.00	0.25	0.24	408.90	0.41	0.24	596.20	0.60	0.24	810.80	0.81	1.53	1180.10	1.18	1.53	1602.90	1.60	1.53	2596.40	2.60	1.53

## PDX Flat Site Trench Storage Capacity & Cross Section Area

Lay out the length of trench for the site. Determine the maximum storage volume required for this trench run. Divide volume storage by trench length. In "Trench

Storage Capacity" below, find which trench widths and depths provide sufficient storage and select the one that is best for the application.

Channel Depth	6"		8"		10"		12"		15"		18"		24"	
	Gal/Ft	In <sup>2</sup>	Gal/Ft	In <sup>2</sup>	Gal/Ft	In <sup>2</sup>	Gal/Ft	In <sup>2</sup>	Gal/Ft	In <sup>2</sup>	Gal/Ft	In <sup>2</sup>	Gal/Ft	In <sup>2</sup>
3.94	1.10	21.20	1.51	29.07	1.92	36.95	2.33	44.82	2.94	56.63	3.56	68.44	4.78	92.07
5.91	1.71	33.01	2.33	44.82	2.94	56.63	3.56	68.44	4.48	86.16	5.40	103.88	7.24	139.31
7.87	2.33	44.82	3.15	60.57	3.96	76.32	4.78	92.07	6.01	115.69	7.24	139.31	9.69	186.55
9.84	2.94	56.63	3.96	76.32	4.99	96.00	6.01	115.69	7.54	145.22	9.08	174.74	12.15	233.80
11.81	3.56	68.44	4.78	92.07	6.01	115.69	7.24	139.31	9.08	174.74	10.92	210.18	14.60	281.04
13.78	4.17	80.26	5.60	107.81	7.03	135.37	8.46	162.93	10.61	204.27	12.76	245.61	17.05	328.29
15.75	4.78	92.07	6.42	123.56	8.06	155.06	9.69	186.55	12.15	233.80	14.60	281.04	19.51	375.53
17.72	5.40	103.88	7.24	139.31	9.08	174.74	10.92	210.18	13.68	263.33	16.44	316.48	21.96	422.78
19.69	6.01	115.69	8.06	155.06	10.10	194.43	12.15	233.80	15.21	292.85	18.28	351.91	24.42	470.02

Channel Depth	152 mm		203 mm		254 mm		305 mm		381 mm		457 mm		610 mm	
	L/M	M <sup>2</sup>	L/M	M <sup>2</sup>	L/M	M <sup>2</sup>	L/M	M <sup>2</sup>	L/M	M <sup>2</sup>	L/M	M <sup>2</sup>	L/M	M <sup>2</sup>
100	13.68	0.01	18.76	0.02	23.84	0.02	28.92	0.03	36.54	0.04	44.16	0.04	59.40	0.06
150	21.30	0.02	28.92	0.03	36.54	0.04	44.16	0.04	55.59	0.06	67.02	0.07	89.88	0.09
200	28.92	0.03	39.08	0.04	49.24	0.05	59.40	0.06	74.64	0.07	89.88	0.09	120.36	0.12
250	36.54	0.04	49.24	0.05	61.94	0.06	74.64	0.07	93.69	0.09	112.74	0.11	150.84	0.15
300	44.16	0.04	59.40	0.06	74.64	0.07	89.88	0.09	112.74	0.11	135.60	0.14	181.32	0.18
350	51.78	0.05	69.56	0.07	87.34	0.09	105.12	0.11	131.79	0.13	158.46	0.16	211.80	0.21
400	59.40	0.06	79.72	0.08	100.04	0.10	120.36	0.12	150.84	0.15	181.32	0.18	242.28	0.24
450	67.02	0.07	89.88	0.09	112.74	0.11	135.60	0.14	169.89	0.17	204.18	0.20	272.76	0.27
500	74.64	0.07	100.04	0.10	125.44	0.13	150.84	0.15	188.94	0.19	227.04	0.23	693.58	0.69

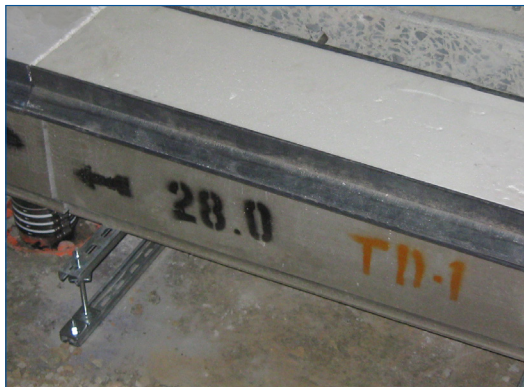

## Sealants

Usually the encasement concrete forms a suitable seal for the trench drain system. However, some applications require sealing the joints to minimize seepage leaks. Three options are available for those occasions.

**PolySeal 1** is a single-part polyurethane in a standard paper caulk tube, and is used as a general purpose sealant for gray water applications.

**PolySeal 4** is a high strength chemical resistant 2 part epoxy with static mixing nozzle. It is a non-sag sealant with 5 minute set up time, ideal for automotive fluids and most cleaners.

**PolySeal 5** is a fast set, high strength, epoxy used for extreme corrosive conditions. Test coupons required to verify chemical resistance for specific applications. It is recommended for sealing joints in PolyChampion installations and ideal for bonding all PolyDrain fabrications and miters. PolySeal 5 requires a static mixing nozzle.

# Grate Options

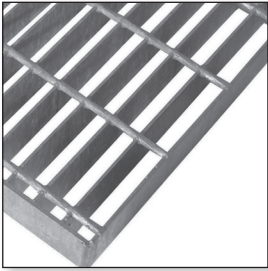

#208  
Banded Bar Grating



#502  
High Intake Slotted



#504  
8" Slotted ADA



#504  
12" Slotted ADA

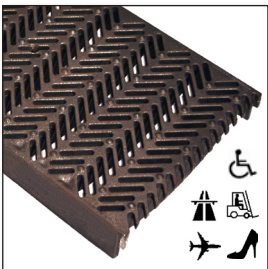

#506  
Herringbone



#603  
Standard Slotted



#606  
Slotted Heel Proof



#501/601  
Solid Cover

## Banded Bar Grating — 208 Series

Part No.	Trench Width	Load Class	Locking Mech.	Grate Length	Angle Size	Weight (lbs)	Open Area (ft² per lin ft)
12.208C.FG	12"	C	1	24"	1.75"	19	0.9

## High Intake Slotted — 502 Series

Part No.	Trench Width	Load Class	Locking Mech.	Grate Length	Angle Size	Weight (lbs)	Open Area (ft² per lin ft)
06.502E.FE	6"	E	1	24"	1.75"	21	0.48
08.502E.GB	8"	E	1,2	19.64"	2"	18	0.47
12.502D.FB	12"	D	1	18"	1.75"	26.1	0.76
12.502E.GB	12"	E	1,2	19.64"	2"	35	0.81
18.502E.GB	18"	E	1,2	19.64"	2"	48	1.25

## Slotted ADA — 504 Series

Part No.	Trench Width	Load Class	Locking Mech.	Grate Length	Angle Size	Weight (lbs)	Open Area (ft² per lin ft)
08.504E.FE	8"	E	1	16"	1.75"	21	0.27
12.504G.FB	12"	G	1	18"	1.75"	51	0.25

## Slotted ADA — 506 Series

Part No.	Trench Width	Load Class	Locking Mech.	Grate Length	Angle Size	Weight (lbs)	Open Area (ft² per lin ft)
08.506F.GB	8"	F	1,2	19.64"	2"	24	0.3

## Standard Slotted — 603 Series

Part No.	Trench Width	Load Class	Locking Mech.	Grate Length	Angle Size	Weight (lbs)	Open Area (ft² per lin ft)
06.603D.FB	6"	D	0	24"	1.75"	37	0.2
08.603D.FB	8"	D	0	24"	1.75"	41	0.3
10.603D.FB	10"	D	0	24"	1.75"	53	0.4
15.603D.FB	15"	D	0	24"	1.75"	76	0.5
18.603D.FB	18"	D	0	24"	1.75"	103	0.7
24.603D.FB	24"	D	0	24"	1.75"	143	0.9

## Slotted Heel Proof — ADA - 606 Series

Part No.	Trench Width	Load Class	Locking Mech.	Grate Length	Angle Size	Weight (lbs)	Open Area (ft² per lin ft)
06.606D.FB	6"	D	0	24"	1.75"	47	0.1
08.606D.FB	8"	D	0	24"	1.75"	61	0.1
10.606D.FB	10"	D	0	24"	1.75"	69	0.1
12.606D.FB	12"	D	0	24"	1.75"	89	0.2
15.606D.FB	15"	D	0	24"	1.75"	69	0.2
18.606D.FB	18"	D	0	24"	1.75"	106	0.5

## Solid Cover — 501/601 Series

Part No.	Trench Width	Load Class	Locking Mech.	Grate Length	Angle Size	Weight (lbs)	Open Area (ft² per lin ft)
08.601D.FB	8"	D	0	24"	1.75"	50	-
10.601D.FB	10"	D	0	24"	1.75"	80	-
12.501G.FB	12"	G	1	17.88"	1.75"	55	-
15.601D.FB	15"	D	0	24"	1.75"	95	NA
18.601D.FB	18"	D	0	24"	1.75"	129	-
24.601D.FB	24"	D	0	24"	2"	181	-

\*\*Contact ABT, Inc. at 800-438-6057 for other grate material, pattern, and size options.

## Static Load Classification

Load Class	A	B	C	D	E	F	G
Description	Light Duty	Medium Duty	Heavy Duty	Extra Heavy Duty	Extreme Heavy Duty	Airport Rated	Airport Rated
Typical Application	Pedestrian	Residential	Commercial	Industrial	Highway	Regional Airport	Port/Intermodal
Category Standard Basis	Industry Standard	Industry Standard	Federal A-A60005	AASHTO H-20	AASHTO HS-25	FAA AC-150	Industry Standard
Maximum Proof Load	6,000 Lbs	12,150 Lbs	25,000 Lbs	40,000 Lbs	50,000 Lbs	100,000 Lbs	200,000 Lbs
Proof Load Pressure	75 psi	150 psi	310 psi	494 psi	620 psi	Variable	2469 psi

- ADA Compliant** - Grate's slot width does not exceed 1/2 Inch in the predominant travel direction.
- Hard Tire Rated** - TFX rails, PDX rails, and PolyDrain frames are Hard Tire Fork Lift Rated to grate and encapsulation concrete load limits.
- Heel Proof Rated** - Grate's slot width does not exceed 5/16 Inch.
- Dynamic Load Rated** - Grates, rails, frames, and grate retention are designed for 0.7g transverse and longitudinally dynamic loads.
- Airport Rated** - Designed for both large vertical and dynamic loads. Common conditions in Airport, Port, and Intermodal applications.

**Locking Mechanism**  
 0 = Non-Locking  
 1 = Toggle Lock  
 2 = Pin Lock

# PolyDrain PDX Run Assembly

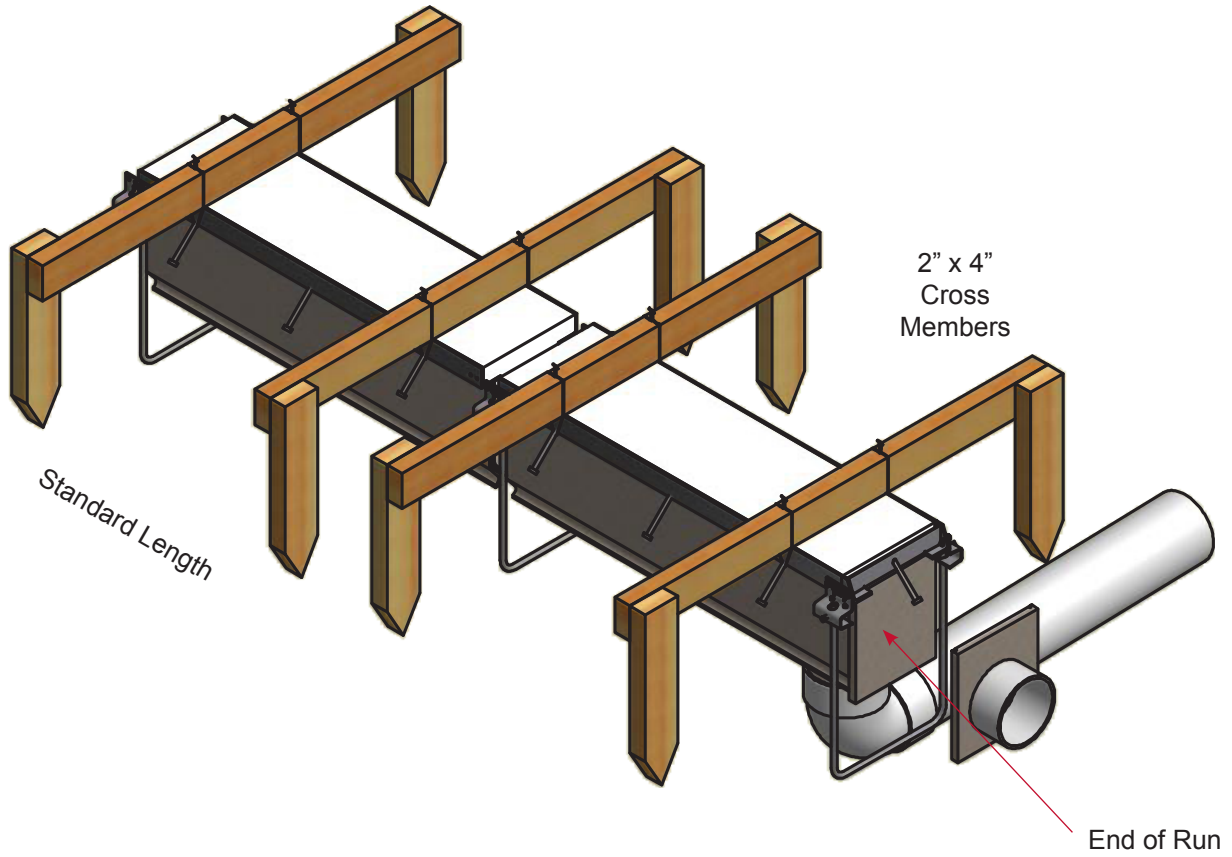

## Rail Connection

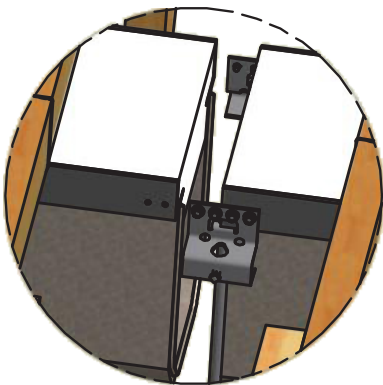

Drive Screws into  
Preformed Holes

## Adjustable Up & Down

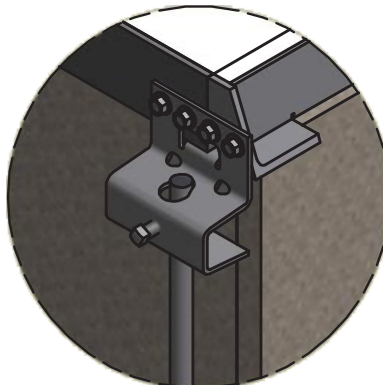

U-Legs are  
Adjustable Up & Down

## End of Run

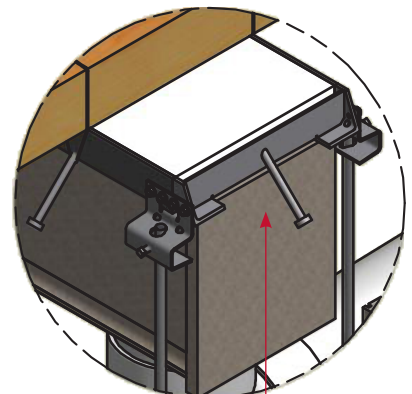

End Frame Connection

# PolyDrain®

Polymer Concrete

## PDX®

Versatile Modular Trench System

Visit our website, [www.abtdrains.com](http://www.abtdrains.com) for the latest details, specifications, catalog updates

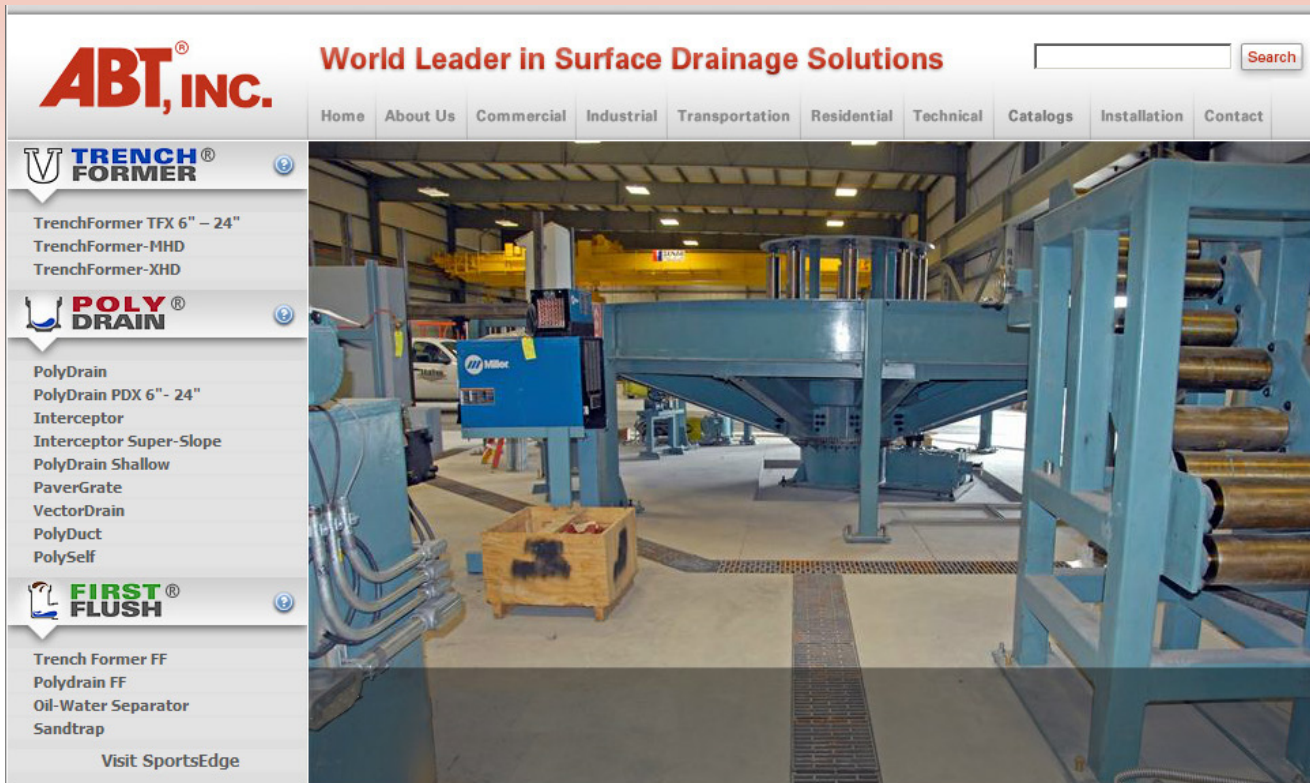

**DISCLAIMER:** The customer and the customer's architects, engineers, consultants and other professionals are completely responsible for the selection, installation, and maintenance of any product purchased from ABT, and EXCEPT AS EXPRESSLY PROVIDED IN ABT'S STANDARD WARRANTIES, ABT MAKES NO WARRANTY, EXPRESS OR IMPLIED, AS TO THE SUITABILITY, DESIGN, MERCHANTABILITY, OR FITNESS OF THE PRODUCT FOR CUSTOMER'S APPLICATION. Copies of ABT's standard warranties are available at [www.abtdrains.com](http://www.abtdrains.com).

The information contained within is believed to be accurate but not guaranteed to be so. The customer should evaluate the suitability and safety of these products for any application. ABT assumes no liability for the end results since the conditions of installation and use are beyond the control of ABT. Concrete specifications, placement, reinforcement and structural considerations are the responsibility of the customer. ABT reserves the right to change the price, availability, specifications, and content of any of its products, literature or other information in all media at any time without notification.

PolyDrain®, PolyDyn®, PolyChampion®, GreenDot®, RedDot®, PolyWall®, TrenchFormer® are registered trademarks of ABT, Inc.®. USA Patent Numbers 5,281,051; 5,348,421; 5,393,171; 5,399,047; 5,573,350; 5,702,204; 5,890,839; 6,443,656; 6,533,497; 6,926,245 : Canada 2,080,136; 2,131,866; 2,131,867; 2,139,405; 2,139,407 : Mexico 189,218; 189,436; 197,851 : Other US and foreign patents pending.



Advanced Building Technologies, Inc.

PO Box 837 | 259 Murdock Road | Troutman, NC 28166

toll-free 800.438.6057 • phone: 704.528.9806 • fax: 704.528.5478

[www.abtdrains.com](http://www.abtdrains.com)