

Plan Notes

Series Number: PD-2519H-AF

1. Grate & Frame:

- Ductile Iron per ASTM A536 Grade 80-55-06 (Uncoated)
- Load Rating: 494 PSI (AASHTO M-306 Test Method)
- Made in the USA

2. Concrete: Concrete Thickness and Reinforcement per Structural Engineer's Specification for the Application.

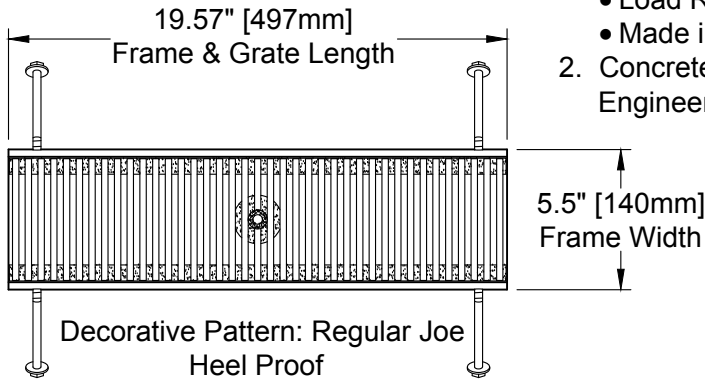

Frame & Grate Top View

(ROTATED 90°)

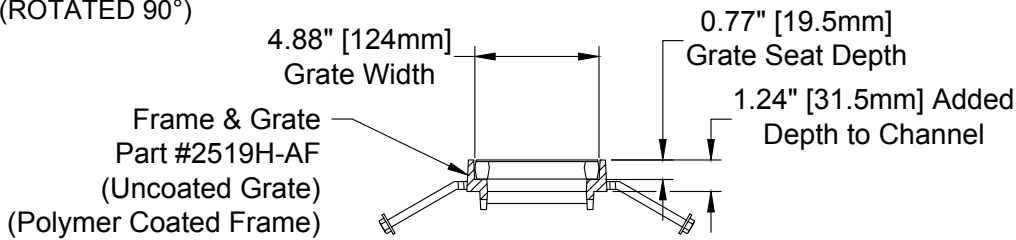

Frame & Grate End View

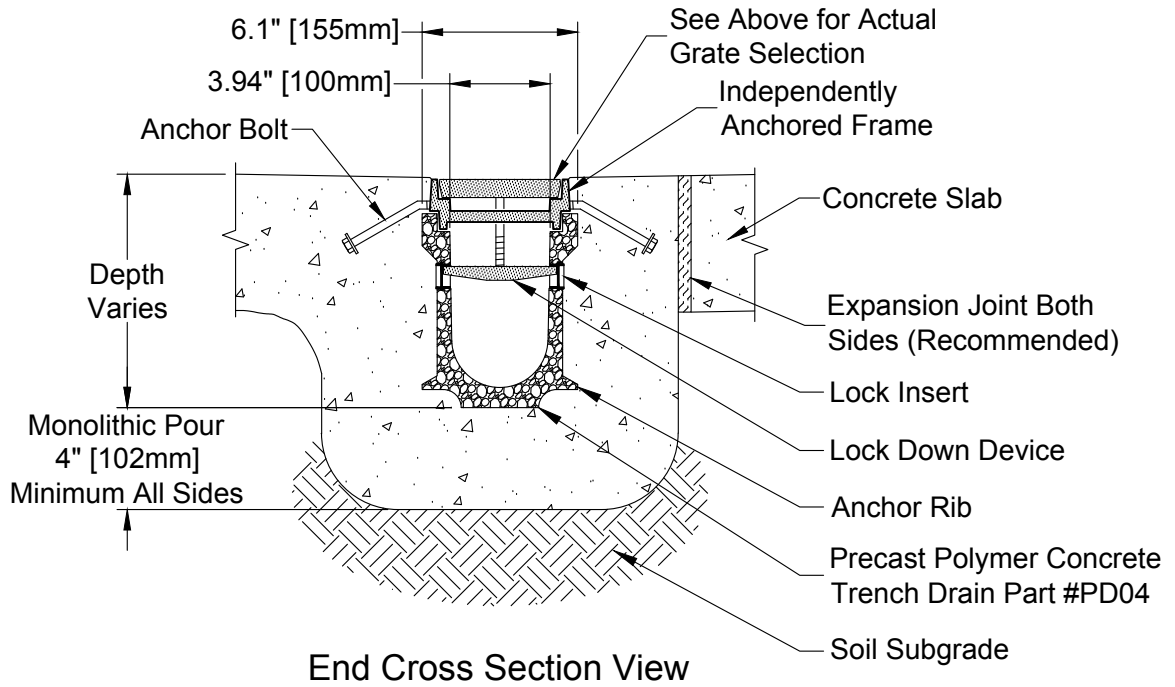

End Cross Section View

Copyright © 2010 ABT, Inc.

ABT, INC.
P.O. BOX 837, 259 MURDOCK ROAD
TROUTMAN, NC 28166
(704) 528-9806

**PolyDrain - 4" [100mm] ID Precast Trench Drain
w/ Uncoated Decorative Grate & Polymer Coated Frame**

SERIES: PD-2519H-AF (Regular Joe - Heel Proof)

REV: 00

Proprietary rights of ABT, Inc. are included in the information disclosed herein. The recipient, by accepting this document, agrees that neither this document nor the information disclosed herein nor any part thereof shall be copied, reproduced or transferred to others for manufacturing or for any other purpose except as specifically authorized in writing by ABT, Inc.

DISCLAIMER: The customer and the customer's architects, engineers, consultants and other professionals are completely responsible for the selection, installation, and maintenance of any product purchased from ABT, and EXCEPT AS EXPRESSLY PROVIDED IN ABT'S STANDARD WARRANTIES, ABT MAKES NO WARRANTY, EXPRESS OR IMPLIED, AS TO THE SUITABILITY, DESIGN, MERCHANTABILITY, OR FITNESS OF THE PRODUCT FOR CUSTOMER'S APPLICATION. Copies of ABT's standard warranties are available upon request.